

SUMMER WAVES® CARTRIDGE FILTER PUMP

FOR ABOVE GROUND SWIMMING POOLS

Model RX330

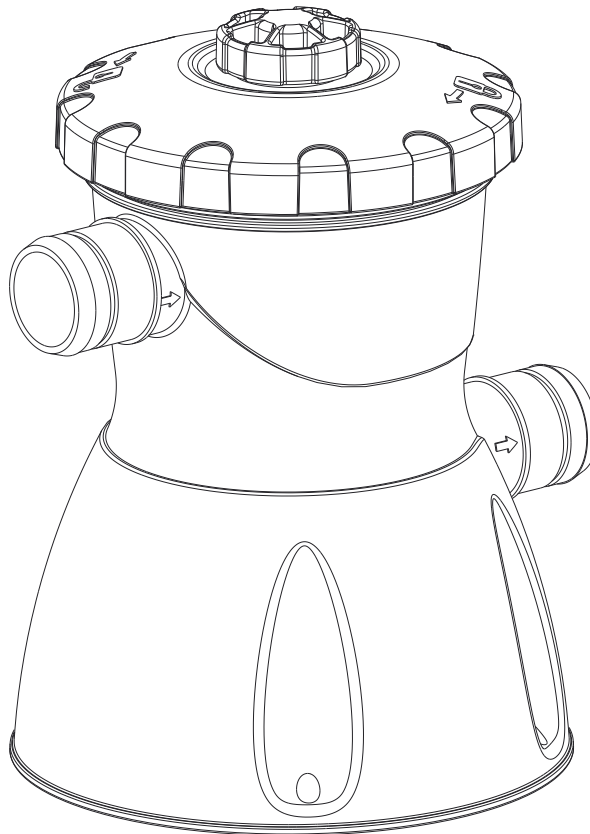

READ AND KEEP THESE INSTRUCTIONS FOR FUTURE REFERENCE

For answers to common questions, setup videos and troubleshooting tips, please visit support.polygroupstore.com or call Customer Service: +1 (888) 919-0070

DO NOT RETURN PRODUCT TO STORE



To order parts and accessories, please visit www.polygroupstore.com



Should you encounter a problem with your Polygroup® Product, please DO NOT return the product to the place of purchase. All warranty claims must be made directly to Polygroup®. For any setup and troubleshooting issues, please visit support.polygroupstore.com. Customer Service: +1 (888) 919-0070. You may be asked to return all or part of the product for inspection and/or repair. Do not return any product to Polygroup® without a Return Merchandise Authorization number.

TABLE OF CONTENTS

| | |
|--|---------|
| Warnings | 3 ~ 6 |
| Preliminary steps, Important notes & Pump power info | 7 |
| Parts list | 7 ~ 9 |
| Setup instructions | 10 ~ 11 |
| Use of pump, Motor care, Maintenance | 12 |
| Filter cartridge use & care | 12 ~ 13 |
| Pool water care | 13 |
| Pump disassembly & storage | 14 |
| Pump servicing instructions - Motor removal | 14 |
| Pump servicing instructions - Rotor inspection | 15 |
| Pump servicing instructions - Pump replacement | 16 |
| Troubleshooting guide | 17 |
| Replacement parts ordering info | 18 ~ 19 |
| ASME compliant suction fitting info | 20 |

Limited Warranty

Polygroup® Trading Limited (hereinafter “Polygroup®”) makes products at the best quality we are able to offer. All Polygroup® products have been inspected against defects in materials and workmanship prior to leaving factory. Polygroup® is happy to offer warranty for the repair or replacement of pool products for 90 days from the date of purchase. The provisions of this Limited Warranty only apply to the original purchaser. Please keep your original store sales receipt, as this proof of purchase will be required and must accompany warranty claims to Polygroup® or its designated agents. This Limited Warranty does not apply without proof of purchase; or should the purchaser modify or repair the product themselves or by unauthorized people; use non-Polygroup® parts or accessories with the product; use the product in contravention of the manufacturer’s instructions; use improper voltage; abuse the product in any way; or through accident or negligence. This Limited Warranty will not cover consequential damages, including claims for loss of water, pool chemicals, damage, or labor, normal wear-and-tear; nor acts of God outside the control of Polygroup®. Non-manufacturing defects, such as grasses that may grow through the ground cloth and/or pool liner are examples of which Polygroup® cannot be held responsible for.

IN NO EVENT SHALL Polygroup®, ITS AUTHORIZED AGENTS, RELATED ENTITIES, OR EMPLOYEES BE LIABLE TO THE BUYER OR ANY OTHER PARTY FOR DIRECT OR CONSEQUENTIAL DAMAGES. Some states or countries, or other jurisdictions, do not allow the exclusion or limitation of incidental or consequential damages, so the above limitation or exclusion may not apply to you.

This Limited Warranty is not extended to close-outs, factory seconds, or resold products (i.e. garage sales, online auctions, or online retailers not purchased directly from Polygroup®). Any issues with items purchased from these types of vendors / sellers will need to be addressed through these stores. Items purchased from seasonal stores will be treated with an “All Sales Final” Policy instead.

IMPORTANT SAFETY INSTRUCTIONS

When installing and using this electrical equipment, basic safety precautions should always be followed, including the following:

READ AND FOLLOW ALL INSTRUCTIONS

Keep for future reference. Failure to follow these warnings and instructions can result in serious injury or death to users, especially children.

WARNING

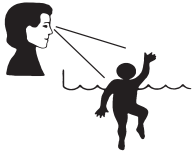

DANGER

PREVENT DROWNING!

WATCH CHILDREN WHO ARE IN OR NEAR THIS POOL CLOSELY. CHILDREN UNDER 5 ARE AT HIGHEST RISK OF DROWNING. EMPTY POOL OR PREVENT ACCESS WHEN NOT IN USE.

NO DIVING!

SHALLOW WATER YOU CAN BREAK YOUR NECK AND BE PARALYSED.

WARNING

DO NOT SIT ON OR LAY OVER POOL WALL
YOU CAN BE PERMANENTLY INJURED.

AVOID ENTRAPMENT!
STAY AWAY FROM DRAINS & SUCTION FITTINGS. YOUR HAIR, BODY & JEWELRY CAN GET SUCKED INTO THE DRAIN. YOU COULD BE HELD UNDER WATER & DROWN. DO NOT USE POOL IF DRAIN OR SUCTION OUTLET COVER IS MISSING OR BROKEN.

NOTICE: CUSTOMERS WHO PURCHASE POOLS MAY BE REQUIRED BY LOCAL OR STATE LAW TO INCUR ADDITIONAL EXPENSES WHEN INSTALLING A POOL, IN ORDER TO COMPLY WITH STATE OR LOCAL LAWS REGARDING FENCING AND OTHER SAFETY REQUIREMENTS. CUSTOMERS SHOULD CONTACT THEIR LOCAL BUILDING CODE ENFORCEMENT OFFICE FOR FURTHER DETAILS. POLYGROUP® IS NOT RESPONSIBLE FOR ANY ADDITIONAL EXPENSES THAT YOU MAY INCUR.

Safety Care for Children

1. Children, especially children younger than five years, are at high risk of drowning. Drowning occurs silently and quickly and can occur in as little as 2 in (5 cm) of water.
2. Keep children in your direct sight, stay close, and actively supervise them when they are in or near this pool and when you are filling and emptying this pool.
3. When searching for a missing child, check the pool first, even if the child is thought to be in the house.
4. Locate pumps and filters in such a way that children cannot climb on them and gain access to the pool.
5. **WARNING:** To reduce the risk of injury, do not permit children to use this product unless they are closely supervised at all times.

Swimming Pool Barriers

Very Important:

Swimming pool barriers, which restrict access to the pool by small children, may be required by law. A barrier is necessary to provide protection against potential drowning and near drowning. Barriers are not a substitute for constant supervision of children. Check state or local laws and codes before setting up the pool.

Swimming Pool Equipment

1. The use of artificial pool lighting is at the discretion of the pool owner. Lighting, when installed, should be in accordance with Article 680 of the National Electrical Code (NEC®) or its latest approved edition and in consultation with a licensed electrical professional.
2. Keep all electrical lines, radios, speakers, and other electrical appliances away from the pool.
3. Do not place the pool near or under overhead electrical lines.
4. All electrical components installed in and/or adjacent to an above-ground/on-ground residential swimming pool shall be installed in accordance with and shall comply with the requirements of the latest published edition of NFPA 70, National Electrical Code (NEC®) Article 680 "Swimming Pools, Fountains, and Similar Installations", and any state or local code.

Filter Pump Awareness

1. **WARNING:** Risk of electric shock. Connect only to a grounding type receptacle. This product is provided with a ground-fault circuit-interrupter. If replacement of the plug or cord is needed, use only identical replacement parts.
2. **WARNING:** To reduce the risk of electric shock, replace damaged cord immediately.
3. **WARNING:** To reduce the risk of electric shock, do not use the extension cord to connect the unit to the electric supply; provide a properly located outlet.
4. **CAUTION:** To reduce the risk of electric shock, the pool must be installed no closer than 6 feet (1.83 m) from any electrical outlet. Do not place portable appliances closer than 5 feet (1.5 m) to the pool.
5. **CAUTION:** This pump is for use with storable pools only. Do not use with permanently-installed pools. A storable pool is constructed so that it is capable of being readily disassembled for storage and reassembled to its original integrity. A permanently-installed pool is constructed in or on the ground or in a building such that it cannot be readily disassembled for storage.

6. **CAUTION:** For continued protection against possible electric shock, this unit is to be mounted to the base in accordance with the installation instructions.
7. Do not bury the cord. Locate cord to minimize abuse from lawn mowers, hedge trimmers, and other equipment.
8. The unit is provided with a ground-fault circuit-interrupter (GFCI). To test the GFCI, push the test button. The GFCI should interrupt power. Push the reset button. Power should be restored. If the GFCI fails to operate in this manner, the GFCI is defective. If the GFCI interrupts power to the pump without the test button being pushed, a ground current is flowing, indicating the possibility of an electric shock. Do not use this pump. Disconnect the pump, and have the problem corrected by a qualified service representative before using.
9. The Filter Pump is to be assembled by an adult; care should be taken in the unpacking and assembling of the Filter Pump. This pool may contain accessible potentially hazardous sharp edges or sharp points that are a necessary part of the function of the Filter Pump.
10. If a drain or suction outlet cover is missing or broken, do not use the pool. Suction can cause body part entrapment, hair and jewelry entanglement, evisceration, or drowning. Repair or replace the drain or suction outlet cover before allowing the pool to be used. During nighttime pool use, artificial lighting shall be used to illuminate all safety signs, ladders, steps, deck surfaces, and walks.
11. The floor of the pool shall be visible at all times from the outside perimeter of the pool.
12. Post a list of emergency telephone numbers such as the nearest available police, fire, ambulance, and/or rescue unit. These numbers are to be kept near the telephone that is closest to the pool.
13. Basic lifesaving equipment, including one of the following should be on hand at all times:
 - A light, strong, rigid pole (shepherd's crook) not less than twelve feet (12') [366 cm] long.
 - A minimum one-fourth inch (1/4") [6.35 mm] diameter rope as long as one and one half (1 1/2) times the maximum width of the pool or fifty feet (50') [15.24 meters], whichever is less, which has been firmly attached to a Coast Guard-approved ring buoy having an outside diameter of approximately fifteen inches (15") [38.1 cm], or similarly approved flotation device.
14. Pool shall be located at a minimum distance of 6 ft (1.83 m) from any receptacle, and all 125-volt 15- and 20-ampere receptacles located within 20 ft (6.0 m) of the pool shall be protected by a ground fault circuit interrupter (GFCI), where distances are by measuring the shortest path the supply cord of an appliance connected to the receptacle would follow, without piercing a floor, wall, ceiling, doorway with hinged or sliding door, window opening, or other effective permanent barrier, to the inside pool wall.

Circulation Systems

1. The installer shall follow written instructions regarding positioning of all equipment connected to the circulation systems.
2. The installer shall follow written instructions provided for operating the circulation system components.
3. All circulation system components and pump that require replacement or servicing shall be installed according to the pump's instruction manual.
4. Circulation equipment shall be installed per manufacturer's instructions to provide proper mounting and support, to prevent damage from misalignment, settlement, and vibration, and to minimize the potential for the accumulation of debris and moisture. Please refer to pump's instruction manual.

Chemicals

For safety sake, ensure the deepest part of the pool is always visible. The user must properly maintain the clarity of the pool water at all times. Check the pH and chlorine levels periodically and make sure they are within the recommended limits. Additional water treatment chemicals might be needed from time to time. Have the water sample tested by a local pool supply store to determine if additional chemical is needed. Turn on the pump for the recommended hours daily. If you are unsure of the time frames please refer to support.polygroupstore.com for the recommended Pump Operation Hours based on pool types and sizes. Clean and replace filter cartridge frequently. Replace only with a genuine Polygroup® / Summer Waves® Brand filter cartridge. Refer to the Filter Pump manual for additional water care information.

Risk of Entrapment

1. **Entrapment Avoidance:** There shall be no protrusions or other obstruction in the swimming area, which may cause entrapment or entanglement of the user. If a suction outlet cover is missing or broken, do not use the pool. Suction can cause body part entrapment, hair and jewelry entanglement, evisceration, or drowning. Repair or replace the suction outlet cover before allowing the pool to be used.
2. **DANGER! TO AVOID SERIOUS INJURY OR DEATH, CLOSE THE POOL OR SPA TO BATHERS IF ANY SUCTION OUTLET COVER/GRATE IS MISSING, BROKEN, OR INOPERATIVE.**
3. Never play or swim near drains or suction fittings. Your body or hair may be trapped causing permanent injury or drowning.
4. Never enter the pool or spa if a suction fitting or drain cover is loose, broken, or missing.
5. Immediately notify the pool/spa owner or operator if you find a drain cover loose, broken, or missing.

Risk of Drowning

1. Keep unsupervised children from accessing the pool by installing fencing or other approved barriers around all sides of pool. State or local laws or codes may require fencing or other approved barriers. Check state or local laws and codes before setting up the pool.
2. Toys, chairs, tables, or similar objects that a young child could climb shall be at least four feet (4') [121.92 cm] from the pool. The pump filter system shall be positioned so as to prevent it being used as a means of access to the pool by young children. Do not leave toys inside pool when no longer in use, as toys and similar items might attract a child to the pool.
3. Position furniture (for example: tables, chairs) away from pool and so that children cannot climb on it to gain access to the pool.

Risk of Electrocutation

1. Keep all electrical lines, radios, speakers, and other electrical appliances away from the pool.
2. Do not place the pool near or under overhead electrical lines.

First Aid

1. Keep a working phone and a list of emergency numbers near the pool.
2. Become certified in cardiopulmonary resuscitation (CPR). In the event of an emergency, immediate use of CPR can make a lifesaving difference.

Special Warning

1. Local building codes may require obtaining a building or electrical permit. Installer shall follow regulations on setback, barriers, devices, and other conditions.
2. Safety signs shall comply with requirements of ANSI-Z535 and use signal wording.
3. DO NOT attempt to assemble this pool in adverse weather conditions, windy conditions, or when the temperature is below 60°F.
4. This is a storable filter pump, which should be disassembled and stored when temperatures are expected to fall below 32°F.

Extra Safety Warning

1. Adult supervision is always required.
2. Parents should learn CPR.
3. Keep all electrical radios, speakers, and other appliances away from the swimming pool.
4. When you touch the filter, pump, or electrical parts, be sure the ground under your feet is "Bone Dry."
5. All electrical outlets should have a GFCI, and connections should be a minimum of 6 feet (1.83 m) from the outside perimeter of the wall of the pool.
From 6–10 feet (1.83–3.05 m), there should be either a fixed connection (outlet box) or twistlock connection with a GFCI.
6. Connect power cords to a 3-wire grounding-type outlet only.
7. Keep all breakable objects out of the pool area.
8. Alcohol consumption and pool activities do not mix. Never allow anyone to swim, dive, or slide under the influence of alcohol or drugs.
9. Severe electrical shock could result if you install your pump or filter on a deck. The pump or filter could fall into the water, causing severe shock or electrocution.
10. Do not install on a deck or other surface at, above, or slightly below the top rail of the pool.
11. Do not use the filter pump during severe weather conditions, i.e. electrical storms, tornadoes, etc.
12. Be aware of overhead power lines when vacuuming your pool or using a telescoping pole.
13. Check regularly for signs of wear or loose bolts that could make the deck unsafe.
14. Please contact pool site dealer or manufacturer for additional safety signs if deemed necessary.
15. For pool service, select a certified pool professional. For additional safety information, see www.APSP.org

Consumer Awareness Booklets and Information Source

Contact: U.S. Consumer Product Safety Commission at www.cpsc.gov/safety-education/safety-guides/pools-and-spas, Pub. #362 "Safety Barrier Guidelines for Home Pools."

1. The Sensible Way to Enjoy Your Above-ground/On-ground Swimming Pool.
2. Children Aren't Waterproof.
3. Layers of Protection.
4. Pool and Spa Emergency Procedures for Infants and Children.
5. Be Safety Aware.

Copies of the above brochures are available free from the APSP at www.APSP.org

Safety Education Programs and Materials

Educational programs and materials (i.e., seminars, workshops, brochures, videos, instructional guides) are available from the APSP, other aquatic safety groups, and from private firms. As a means of communicating useful safety information to pool owners/operators, and users, industry members are permitted to provide such information to owners/operators and to request or require owners/operators to sign a statement that they have received, read, and will follow the guidelines.

Other sources of safety information:

- www.cdc.gov
- www.cpsc.gov
- www.drowningpreventionalliance.com
- www.nspf.org
- www.safekids.org

ANSI American National Standards Institute

25 West 43rd Street, New York NY 10036

Contact: 212-642-4900

www.ansi.org

APSP Association of Pool & Spa Professionals

(formerly National Spa and Pool Institute)

2111 Eisenhower Avenue, Suite 500

Alexandria VA 22314-4679

Contact: 703-838-0083

www.apsp.org

ASME American Society of Mechanical Engineers

Two Park Avenue, New York NY 10016-5990
Contact: 800-843-2763 (U.S. & Canada) 973-882-1170 (outside North America)
www.asme.org

NSPI National Spa and Pool Institute (see APSP)**UL Underwriters Laboratories**

333 Pfingsten Road, Northbrook IL 60062-2096
Contact: 877-854-3577 or 847-272-8800
www.ul.com

NSF NSF International

P.O. Box 130140
789 N. Dixboro Road
Ann Arbor MI 48105
Contact: 800-673-6275 or 734-769-8010
www.nsf.org

ASTM ASTM International (formerly American Society of Testing & Materials)

100 Barr Harbor Drive, P.O. BOX C700
West Conshohocken, PA 19428-2959
Contact: 877-909-2786 (USA & Canada) or 610-832-9585 (International)
www.astm.org

NEC National Electrical Code (see NFPA)

NFPA National Fire Protection Association
1 Batterymarch Park, Quincy MA 02169-7471
Contact: 800-344-3555 (U.S. & Canada) or 617-770-3000 (International)
www.nfpa.org

Filtration Systems

Any equipment connected to the circulation systems shall be positioned so as to prevent their being used as a means of access to the pool by young children. (See the latest published edition of ANSI/APSP-8 Model Barrier Code for Residential Swimming Pools, Spas, and Hot Tubs.)

Barriers

Barriers are necessary to provide protection against potential drowning and near drowning, and barriers are not a substitute for the constant supervision of children. (See latest published edition of ANSI/APSP-8 Model Barrier Code for Residential Swimming Pools, Spas, and Hot Tubs.)

Risk of Drowning, Entrapment, and Diving Accidents

Publications are available that describe the risk of drowning, entrapment, and diving accidents. Available publications related to pool safety include the Association of Pool and Spa Professionals' (APSP) booklets entitled: The Sensible Way to Enjoy Your Above-ground/On-ground Swimming Pool, Children Aren't Waterproof, Pool and Spa Emergency Procedures for Infants and Children, Layers of Protection, and the latest published edition of ANSI/APSP-8 Model Barrier Code for Residential Swimming Pools, Spas, and Hot Tubs.

Installer Responsibilities

All of these components shall be positioned so as to prevent their being used as a means of access to the pool by young children. (See Barrier Code for Residential Swimming Pools, Spas, and Hot Tubs.)

SAVE THESE INSTRUCTIONS

PRELIMINARY STEPS

1. READ ALL INSTRUCTIONS CAREFULLY and get a thorough understanding of what is required to assemble your Filter Pump.
2. It is recommended to have some petroleum jelly (not included) on hand for lubricating the gaskets and o-rings.

IMPORTANT:

1. The installer shall follow the written instructions provided for the operation of the filter pump system.
2. All electrical components shall be installed in accordance with Article 680 of the 2017 National Electrical Code® (NEC®) or its latest approved edition.
3. This Filter Pump is manufactured by Polygroup® and ETL control number 4000608 and 4006317 – double insulated and grounded – 120VAC 60Hz. All units must have a minimum of 105VAC to start and run properly.

FILTER PUMP POWER INFO

| Model | Wattage | Amperage |
|-------|----------|----------|
| RX330 | 30 Watts | 0.5 Amps |

PARTS LIST

| Item | Parts Name | Qty. | Item | Parts Name | Qty. |
|------|------------------------|------|------|------------------------------------|------|
| 1 | Fitting Gasket (black) | 2 | 15 | Gasket Top | 1 |
| 2 | Suction Fitting (SF) | 1 | 16 | Canister Gasket / Motor Seal | 1 |
| 3 | SF Washer | 1 | 17 | Pump Canister | 1 |
| 4 | Fitting Lock Nut | 2 | 18 | Rubber Nozzle | 1 |
| 5 | SF Cap | 1 | 19 | Pump Motor Assembly | 1 |
| 6 | Return Fitting (RF) | 1 | 20 | Type I Filter Cartridge | 1 |
| 7 | RF Diverter | 1 | 21 | Canister Screw | 6 |
| 8 | RF Service Plug | 1 | 22 | Pump Body | 1 |
| 9 | Hose | 2 | 23 | Rotor Assembly | 1 |
| 10 | Hose Clamp | 4 | 24 | Volute Cover | 1 |
| 11 | Filter Pump Assembly | 1 | 25 | Volute Cover Screw | 2 |
| 12 | Vent Screw | 1 | 26 | GFCI Power Cord Set | 1 |
| 13 | Vent Screw O-Ring | 1 | 27 | 1.25" O-Ring (for hose connection) | 4 |
| 14 | Seal Top | 1 | | | |

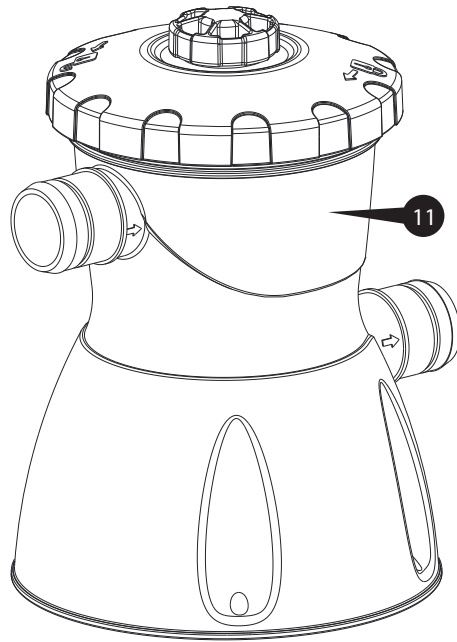

RETURN FITTING

SUCTION FITTING

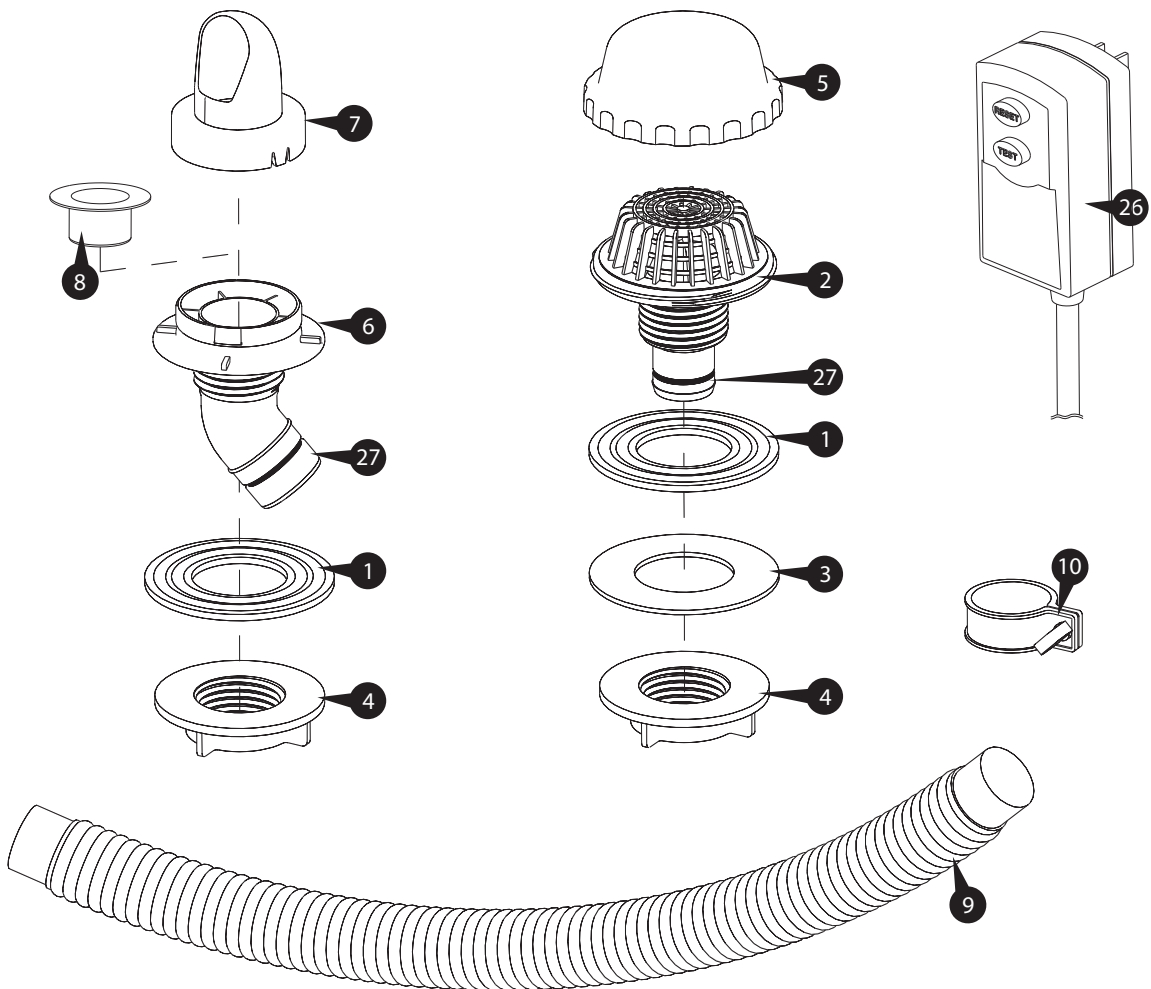

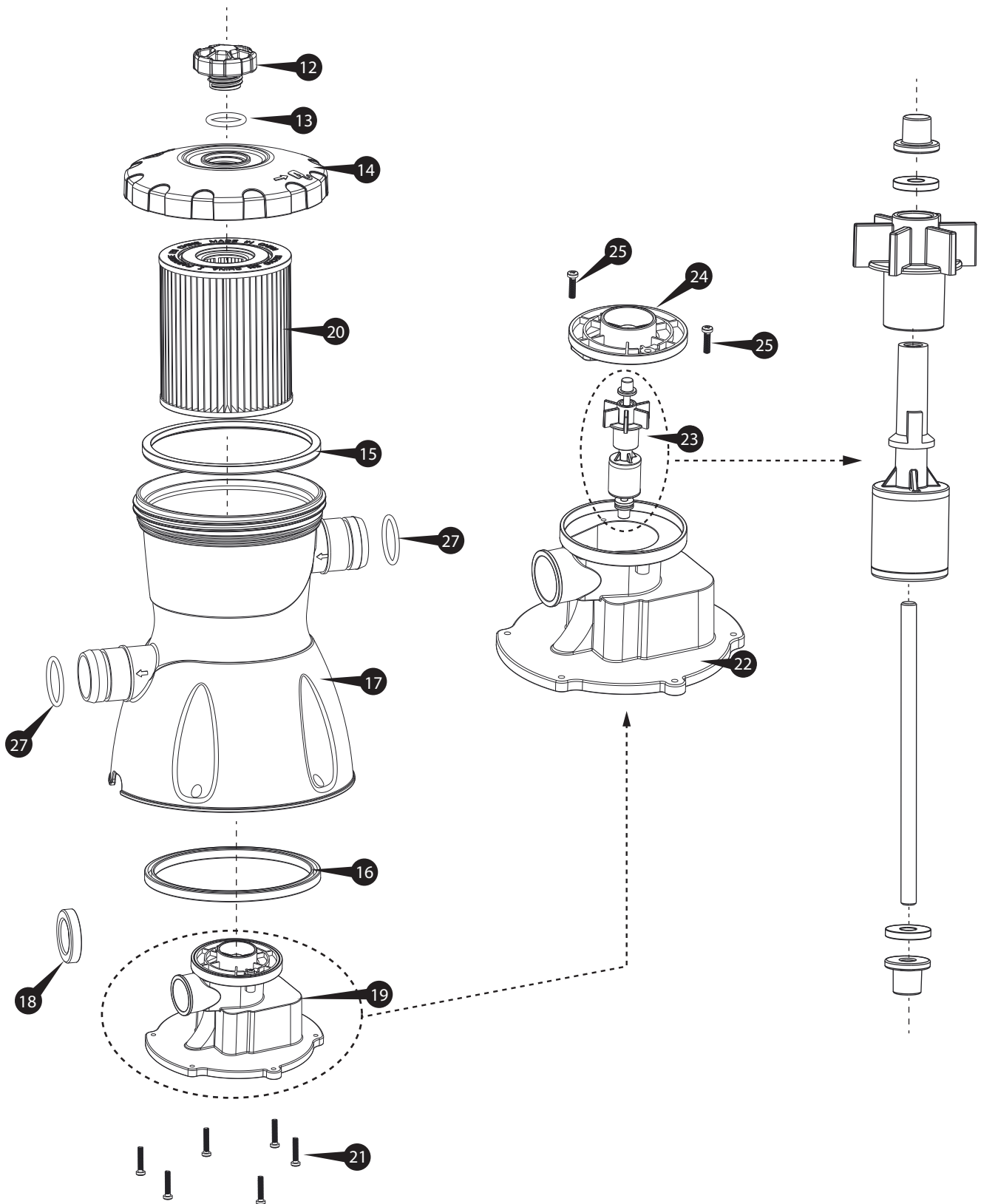

SETUP INSTRUCTIONS

Before assembly, take a few minutes to identify and become familiar with all the parts.

⚠ WARNING: CLIMBING HAZARD! PLEASE PREVENT CHILDREN FROM CLIMBING ON THE FILTER CANISTER TO GAIN ACCESS TO THE POOL.

Suction & Return Fittings Installation

1. Set up your pool following the pool Owner's Manual instructions. Do NOT fill water until the Filter Pump is properly installed. Locate the Outlet and Inlet openings on the pool wall.

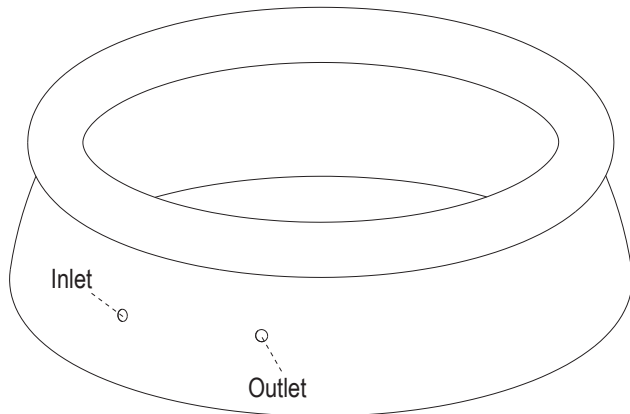

2. From inside the pool, install the Suction Fitting **2** into the Outlet opening.

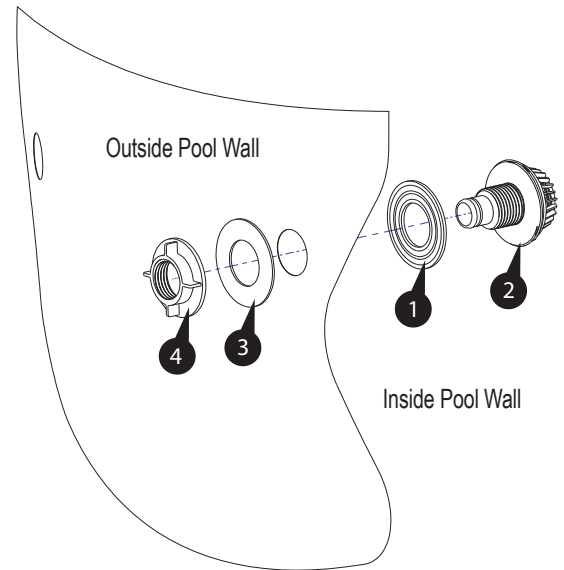

3. From inside the pool, install the Return Fitting **6** into the Inlet opening.

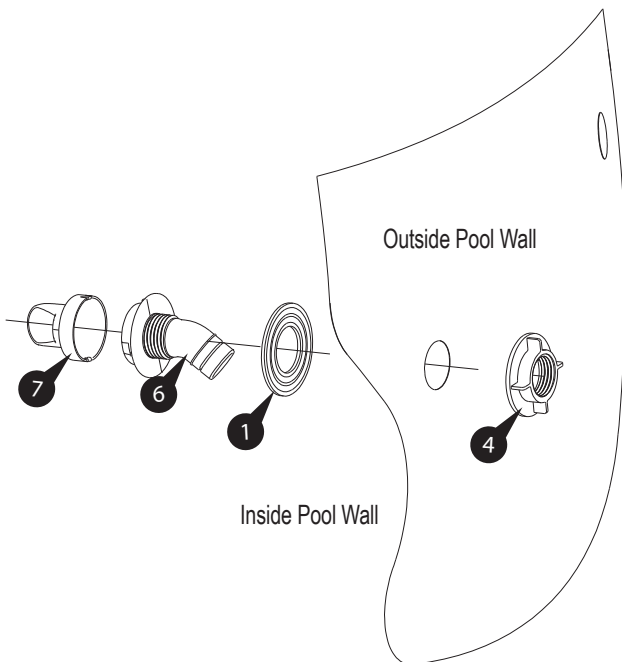

Pump Installation

4. Take out the Filter Pump Assembly **11**, two Hoses **9** and four Hose Clamps **10**.

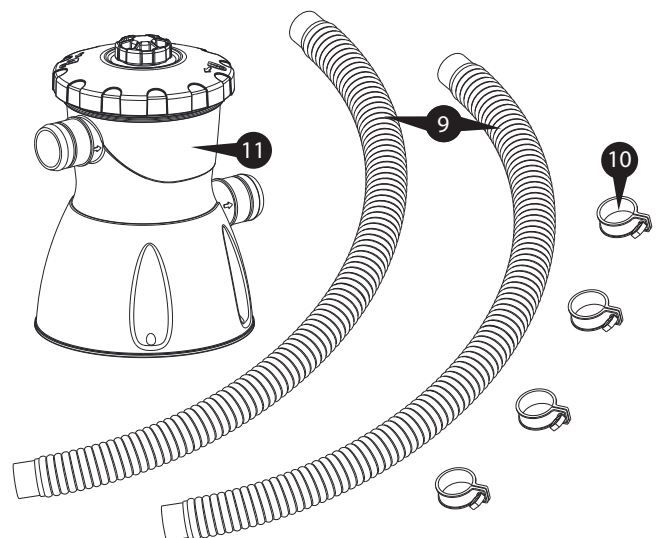

5. Connect the Suction Fitting **2** to the Pump inlet with a Hose and one Clamp on each end.

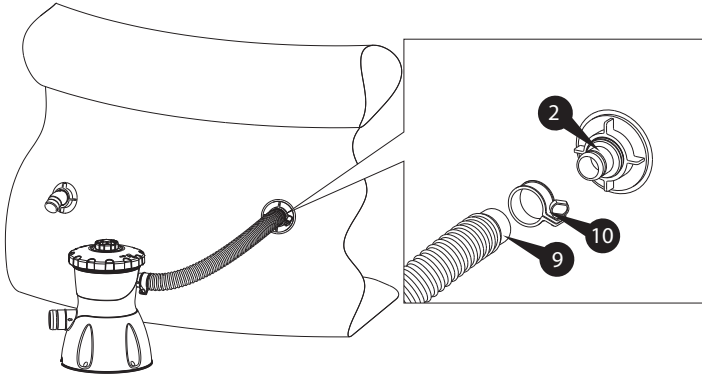

6. Connect the Return Fitting **6** to the Pump outlet with another Hose and one Clamp on each end.

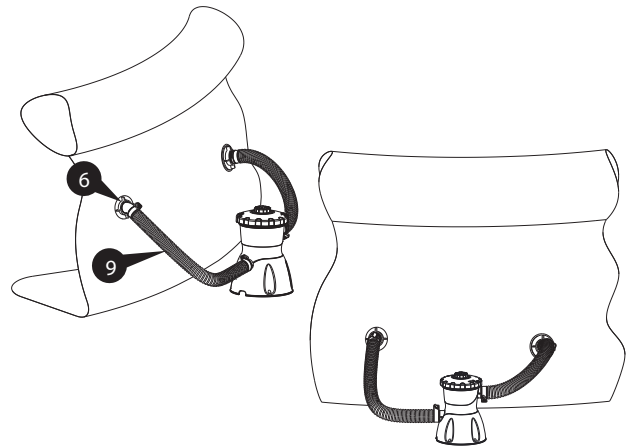

7. Tighten all the Clamps **10** to prevent water leakage.

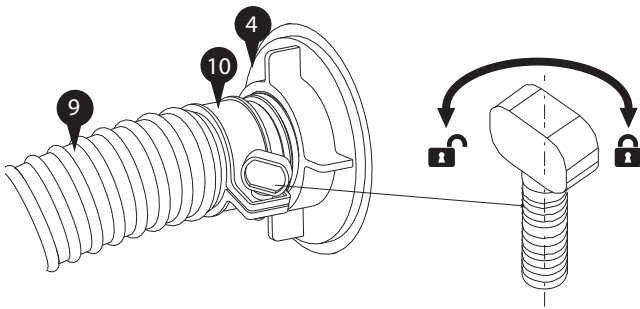

9. **Vent the Pump:** to release the air trapped inside and make sure a smooth water flow, it's important to vent or depressurize the Pump before each use. Simply twist counterclockwise to loosen the Vent Screw **12**, and the water pressure will force all the trapped air out. Retighten the Screw when water starts flowing out.

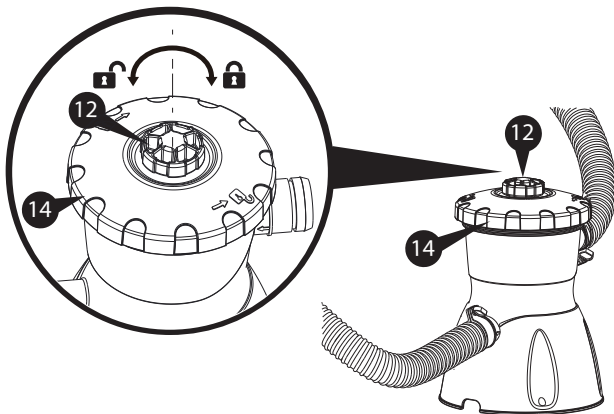

Before Using the Pump

8. You can now fill the pool with water up to the FILL LINE. Do NOT plug the Pump in at this point.

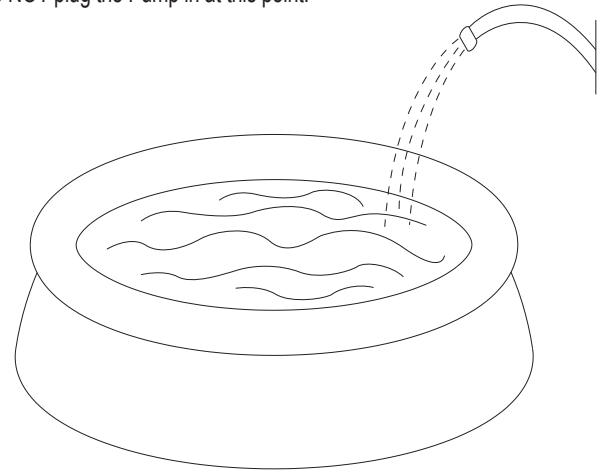

10. To optimize water circulation, twist the RF Diverter **7** so that it faces down and away from the Suction Fitting.

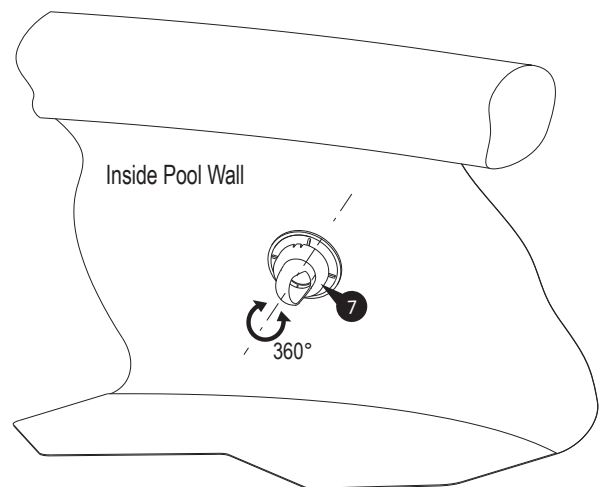

USE OF PUMP

1. Plug the GFCI Power Cord Set 26 to a properly grounded receptacle at least 15 feet (4.5m) away from the pool.
2. To turn on the Pump, press the RESET button of the GFCI Plug.
3. From inside the pool, check if the water flow from the RF Diverter 7 is correct. It should feel like a solid stream of water returning to the pool. If not, or if you feel a reduction in flow, clean or replace the Filter Cartridge 20. For details, see **FILTER CARTRIDGE USE & CARE** below as well as Symptom 2 of **TROUBLESHOOTING GUIDE** (p. 17).
4. To turn the Pump off, press the TEST button of the GFCI Plug, and unplug it from the power outlet.
5. **VERY IMPORTANT:** Check and adjust the pH and chlorine levels daily.
FILTER PUMP ALONE WILL NOT PREVENT ALGAE FROM GROWING IN POOL WATER; THIS CAN ONLY BE DONE BY MAINTAINING PROPER CHLORINE AND pH LEVELS AT ALL TIMES. For details, see **POOL WATER CARE** (p. 13).

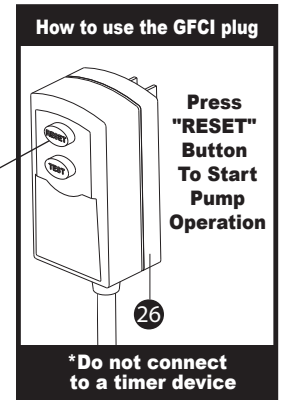
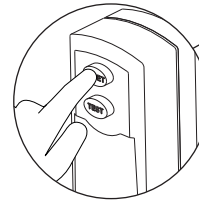

IMPORTANT: Do NOT connect to a timer device!

PUMP MOTOR CARE

IMPORTANT! This Cartridge Filter Pump is protected by a thermal switch, a safety device that stops the pump from running when it's overheated, to prevent pump damage and prolong service life. If your pump turns off automatically, it's likely the pool water temperature is too high or the water flow through the pump is insufficient for cooling the pump down. Check and correct the water flow, make sure motor rest 15 minutes at least and then restart the pump by pressing the RESET button of the GFCI Plug, or run the pump at night when the temperature is lower. If pump turns off automatically again, inspect your pump rotor block by dirt.

PUMP MAINTENANCE

1. Check the pump output daily. If water flow reduces, see Symptom 2 of **TROUBLESHOOTING GUIDE** (p. 17).
2. Check the Pump, Hoses and Fittings for leaks. If a leak is found, see Symptom 4 of **TROUBLESHOOTING GUIDE**.
3. It's essential to replace any damaged parts as soon as possible. Use only spare parts from approved, reliable dealers, or from polygroupstore.com
4. Inspect the filter and all filter media regularly to ensure that there's no build-up of detritus that prevents good filtration. See **FILTER CARTRIDGE USE & CARE** below.
5. Run the Pump for the recommended number of hours daily. If you are unsure of the time frame, please see **Pump Operation Hours** at support.polygroupstore.com.

FILTER CARTRIDGE USE & CARE

1. To clean the Filter Cartridge 20 :
 - a. Unplug the Pump from the power outlet.
 For the Suction Fitting 2 : seal it with the SF Cap 5.
 For the Return Fitting 6 : remove the RF Diverter 7, and seal it with the Service Plug 8.
 - b. Vent the Pump by slowly loosening the Vent Screw 12 counterclockwise. See **SETUP INSTRUCTIONS** (9), p.11.

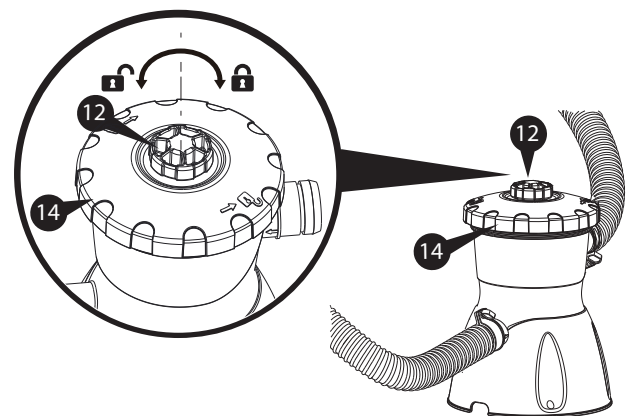
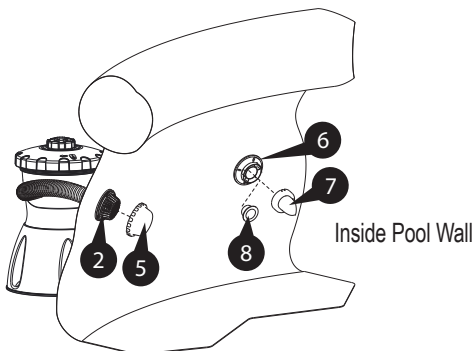

- c. Using both hands, twist counterclockwise to remove the Seal Top 14.

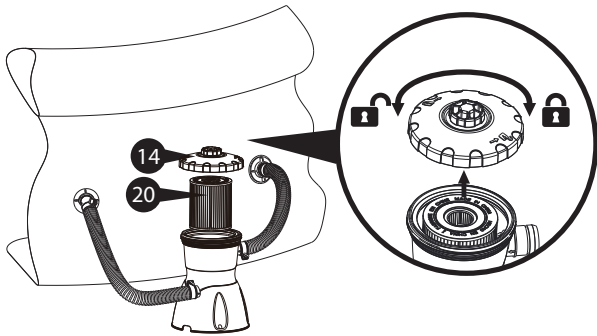

- d. Take the Cartridge out, pressure wash it thoroughly (including between the pleats) with a garden hose to remove larger debris. Allow to dry, then carefully brush away smaller and fine particles of dirt. Do NOT scrub the pleats, or the Cartridge will wear out faster than it should. To ensure pool water stays clean, please clean the filter cartridge every day and change when required.

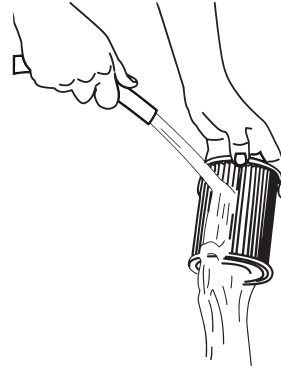

- e. Take the Canister Gasket 15 out and lubricate it liberally with petroleum jelly.
f. Reassemble the parts in reverse order. Before restarting your Pump, make sure that you've removed the SF Cap 5 and Service Plug 8.

2. A spare "stand-by" Cartridge is an excellent investment. You may need to clean or replace the Filter Cartridge when it's dirty, or before the correct chlorine and pH levels are attained. Also, a clean, well-maintained cartridge assures that your Pump will always be ready to operate at peak efficiency.
3. Suntan oils, body oils and algae can quickly build up and clog the pleats of the Cartridge, reducing the filtration efficiency. Therefore, it is imperative to remove such films of oils and/or algae.
To remove oils: mix 1 pound of tri-sodium phosphate (TSP) or any other strong detergent and 5 gallons of water, and soak the Cartridge for 12 hours.
To remove oils AND algae: same as above, and add ½ pint of pool chlorine or 1 pint of liquid household bleach to the solution ONE HOUR BEFORE removing the Cartridge from the solution.
Thoroughly rinse the Cartridge before reusing it.
4. Excessive calcium and/or mineral deposits may also build up in the Cartridge, and requires to be handled differently. Contact and consult your local pool supplies store for solutions/treatment, and maintain an adequate pH level of pool water (see **POOL WATER CARE** below).
5. Dispose of any used filter media in accordance with applicable regulations/legislation.
6. Always use genuine Polygroup® Summer Waves® Filter Cartridges; they are available at the store you purchased your pool or from polygroupstore.com.

POOL WATER CARE

1. The following items are required to get your pool ready for use. They are available at polygroupstore.com or your local pool supplies stores:
- Test kit** – for checking the chlorine and pH levels of the pool water
 - Floating chlorine dispenser (not included) and chlorine tablet** – for water disinfection and prevention of the growth of algae
 - pH control chemicals** – for adjusting the pH level up (soda ash) or down (acid)
 - Algaecides** – to eliminate algae
 - Superchlorinator** – to destroy ("shock") the combined chlorine, ammonia, nitrogen, and organic compounds that build up in pool water over time and with extended use
 - Leaf net with handle** – for removing leaves, trash, insects, etc. from the pool
2. **IMPORTANT:** it is a **MUST** to maintain the chlorine and pH levels at all times:
- Check and adjust the pH and chlorine levels daily. **FILTER PUMP ALONE WILL NOT PREVENT ALGAE FROM GROWING IN POOL WATER; THIS CAN ONLY BE DONE BY MAINTAINING PROPER CHLORINE AND pH LEVELS AT ALL TIMES.**
 - Recommended pH level:** between 7.3 and 7.8
 - Recommended chlorine level:** between 1.0 ppm and 1.6 ppm
 - Superchlorinate your pool at least every other week.
 - Hot weather and heavy use may require the pH and chlorine levels to be maintained on the upper side of the scale as well as a weekly superchlorination.
 - Using a pool and/or solar cover will help maintain the pH and chlorine levels by reducing evaporation of pool water.
 - CAUTION:** High chlorine concentration and low pH level will damage the pool/pool liner. You must follow the instructions on quantity and safe usage of the pool chemicals you use.
NEVER drop lumps or pellets of chemicals into the pool – this may present a hazard to the swimmers and/or damage your pool liner.
3. Clean your pool regularly with a garden-hose-powered vacuum from Polygroup® or any pool supplies stores.
4. Using a foot bath prior to entering the pool will help keep the pool clean.
5. Avoid using well water. If you must use well water, always seek professional advice from your local pool chemical suppliers before adding ANY chemicals into it.
6. Find out the water capacity (in gallon) of your pool from the pool Owner's Manual. You will need it to determine the amount of chemicals required, or when you contact a pool supplies expert for water testing and advice on safe use of chemicals.
- NOTE:** Always follow the manufacturer label directions of the chemicals you choose to use.

PUMP DISASSEMBLY & STORAGE

1. Unplug the Pump from the power outlet.
2. For the Suction Fitting **2** : seal it with the SF Cap **5**.
For the Return Fitting **6** : remove the RF Diverter **7**, and seal it with the Service Plug **8**.
3. Vent the Pump by slowly loosening the Vent Screw **12**.
4. Loosen all four Hose Clamps **10**, detach both the Hoses **9**, and drain any remaining water.
5. Clean and dry all parts, including the Cartridge.
6. Liberally lubricate the Vent Screw O-Ring **13** and Gasket Top **15** with petroleum jelly. Then reassemble them with the Vent Screw, Seal Top and Canister.
7. Put all the parts into an airtight plastic bag, and store in a dry place that remains above 32°F (0°C) at all times.

PUMP SERVICING INSTRUCTIONS

The most efficient way to troubleshoot or replace the Pump is to remove the entire Pump Motor Assembly **19**. The Motor is consisted of a Rotor Assembly **23** and its related parts. If any of its parts is/are broken, or if it is not seated in place between the Volute Cover **24** and the Pump Body **22**, the Rotor will not function properly even in perfect condition.

STEP 1: Removal of the Motor

1. Unplug the Pump from the power outlet.
For the Suction Fitting **2** : seal it with the SF Cap **5**.
For the Return Fitting **6** : remove the RF Diverter **7**, and seal it with the Service Plug **8**.
2. Vent the Pump by slowly loosening the Vent Screw **12**.
3. Detach the Hose Clamps **10** and Hoses **9** attaching to the Pump inlet and outlet.
4. Turn the Pump upside down, and remove the Canister Screws **21**.
5. Take out the Motor Assembly **19**.

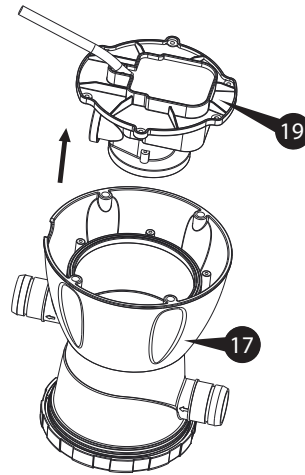
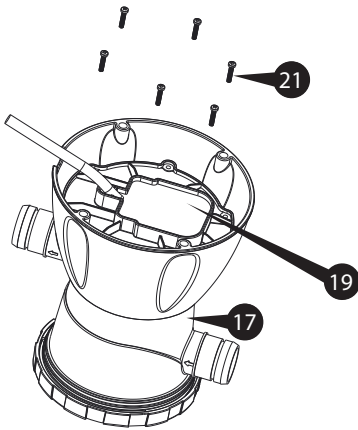

6. Remove the Rubber Nozzle **18**. Be careful not to lose it.

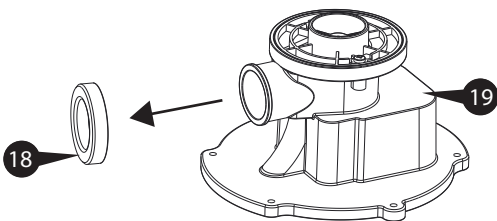

STEP 2: Rotor Inspection/Replacement

1. To take out the Rotor Assembly **23**, simply remove the Volute Cover Screws **25** and pull it out from the Pump Body **22**.
2. Inspect the Rotor (see image below) to make sure that the Rotor Shaft, Magnet Axle, Impeller and other parts are intact. If either of them is broken, you can purchase a new Rotor Assembly from polygroupstore.com without having to replace the whole Pump.
For more details, please see [Pool Support – Filtration System Troubleshooting – RX System](http://support.polygroupstore.com) at support.polygroupstore.com

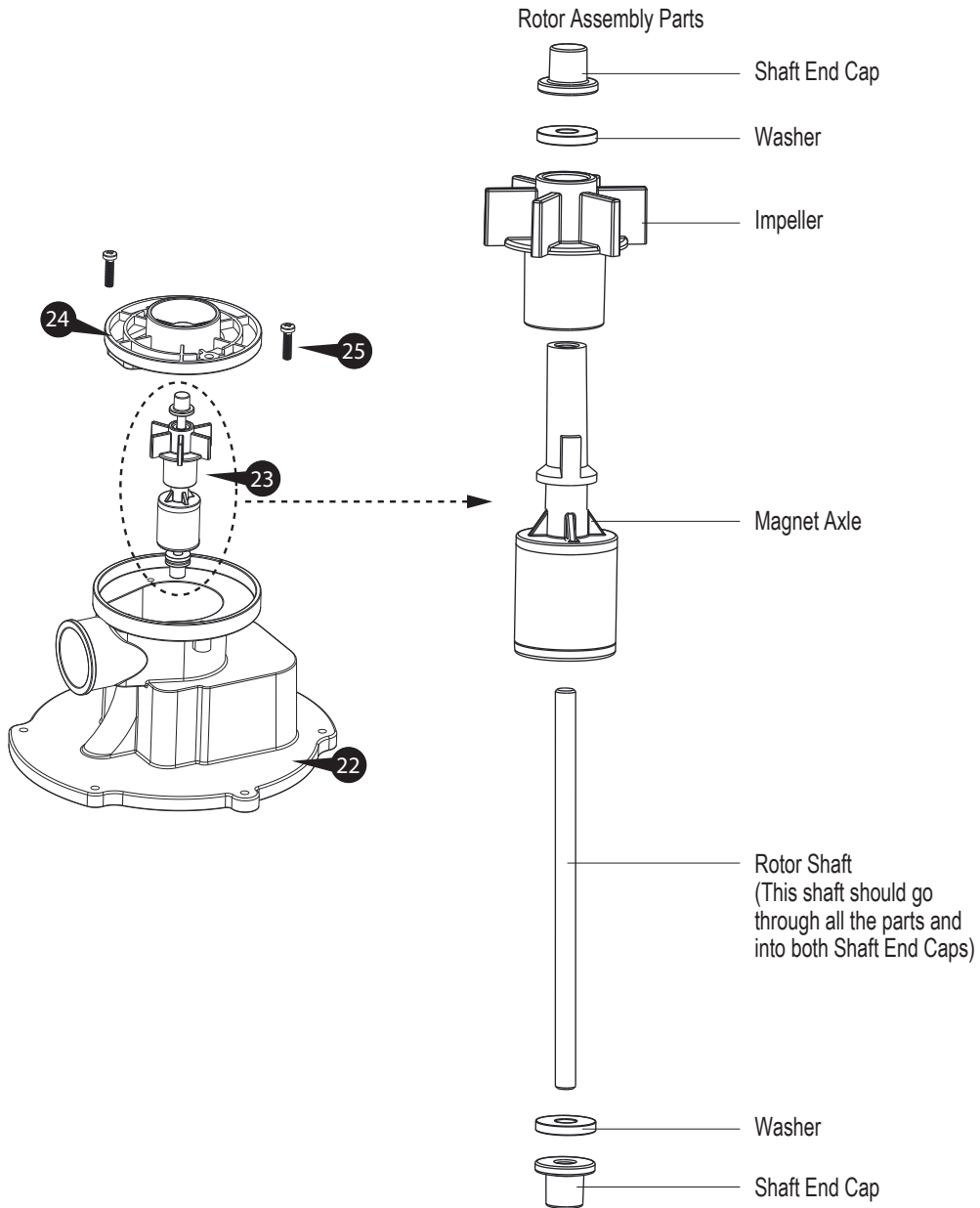

3. Once the inspection or replacement is done, carefully insert the Rotor Assembly back into the Pump Body. The force of the magnet will pull the Rotor down in place.
4. Align the Volute Cover with the top Shaft End Cap, then tighten with the Volute Cover Screws.

STEP 3: Pump Replacement/Reassembly

1. Lubricate the Canister Gasket **16**, then insert it back into the groove at the bottom of the Canister **17**.
2. Attach the Rubber Nozzle **18** to the outlet of the Motor Assembly **19**.

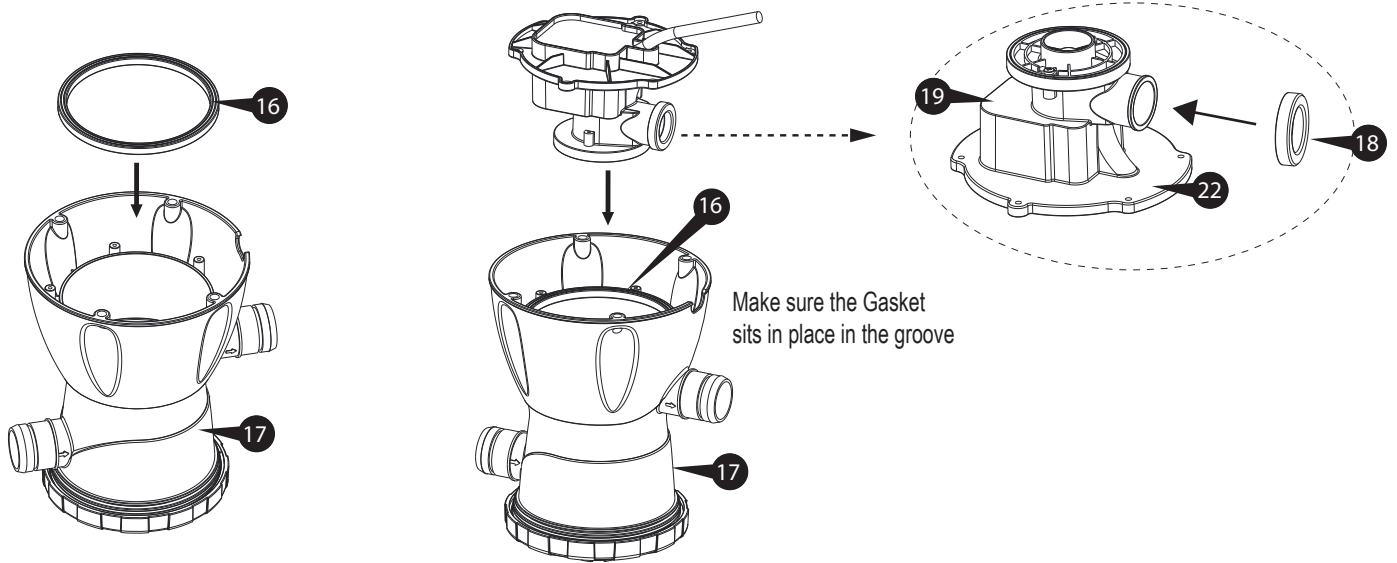



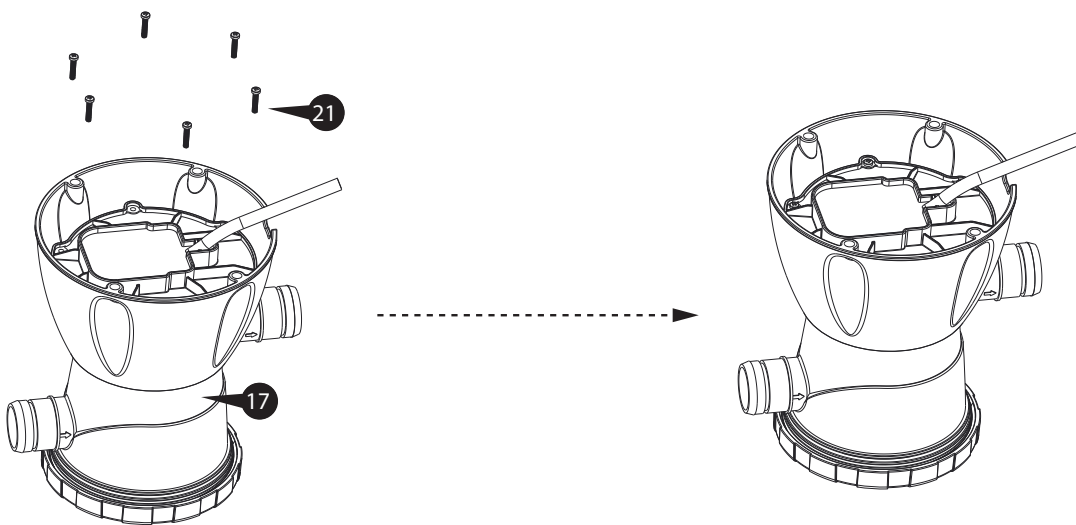







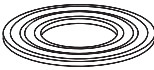

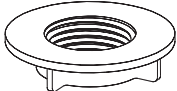

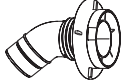
3. Slowly insert the Motor back into the Canister.
4. Tighten the Canister Screws **21**.





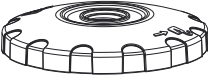









TROUBLESHOOTING GUIDE

| Problem | Cause | Solution |
|---|--|---|
| 1. Motor 19 doesn't start, or kicks on and off | A. Not plugged in | A. Plug the GFCI Power Cord Set 23 to a 3-wire grounded power outlet. Then press the RESET button to restart it. |
| | B. GFCI Power Cord Set 23 and/or circuit breaker tripped | B. Reset your circuit breaker on the electrical panel. If problem persists, have the circuit checked by a qualified electrician. |
| | C. Low voltage | C. Check and make sure the line voltage is between 105V and 125V. |
| 2. No or slow water flow from the Return Fitting 6 | A. Low pool water level | A. Fill the pool to the FILL LINE. The Suction Fitting 2 must be at least 4" under water. |
| | B. Clogged inlet/outlet | B. Check for obstructions at the Filter Cartridge 20, Suction Fitting 2 or Return Fitting 6. |
| | C. The Filter Cartridge 20 is too dirty | C. Clean or replace the Cartridge following the steps of FILTER CARTRIDGE USE & CARE (p. 12) . |
| | D. Motor Rotor block by dirt | D. Refer to pump servicing instructions to clean dirt. |
| 3. Pump is not cleaning the pool properly e.g. cloudy/green water | A. Inadequate chlorine level | A. Maintain the chlorine level between 1.0 and 1.6 ppm. |
| | B. Inadequate pH level | B. Maintain the pH level between 7.3 and 7.8 |
| | C. The Filter Cartridge 20 is too dirty | C. Clean or replace the Cartridge following the steps of FILTER CARTRIDGE USE & CARE (p. 12) . |
| | D. The Filter Cartridge 20 is damaged | D. Inspect the Cartridge for holes or tears. If it's visibly damaged, replace it with a new one. |
| | E. Water flow is slow | E. Check for obstructions at the Filter Cartridge 20, Suction Fitting 2 or Return Fitting 6. |
| | F. Other chemicals required | F. Have your pool water sample tested by a pool supplies store. You may need to add other chemicals since water quality varies in different localities. |
| | G. Pool water is too dirty | G. Chemicals are essential to keep the pool water clean. Clean the pool and filter more often. |
| 4. Water leakage at | A. Suction 2 / Return 6 fittings or Hose 9 connection points | A. Check that the Hose Clamps 11 are properly secured over both the Hoses 9 and their O-rings 27; adjust and retighten if necessary. Also, check the Hoses for cracks or holes and replace as needed. |
| | B. Vent Screw 12 | B. Check the Vent Screw O-Ring 13 for damage and replace as needed. Also retighten the Screw. |
| | C. Seal Top 14 | C. Check the Canister Gasket 15 for damage and replace as needed. Also retighten the Seal Top. |
| | D. Pump Body 22 | D1. Check the Canister Gasket 15 for damage and replace as needed. D2. Check that the Gasket sits correctly in the groove at the bottom of the Canister 17. |

REPLACEMENT PARTS ORDERING INFO

| | | RX330 |
|----|---|--|
| 1 |  | P58PF1520K01 |
| 2 |  | P58281283W05 P582812838UN P582812837CN |
| 3 |  | P58PF1510K01 P58PF15108UN P58PF15107CN |
| 4 |  | P58PF1430W05 P58PF14308UN P58PF14307CN |
| 5 |  | P58PF2820P01 |
| 6 |  | P58PF7800W05 P58PF78008UN P58PF78007CN |
| 7 |  | P58PF7790W05 P58PF77908UN P58PF77907CN |
| 8 |  | P58PF0620K01 |
| 9 |  | P58125036W01 |
| 10 |  | P58220221W05 P582202218UN P582202217CN |
| 12 |  | P58P4119AW05 P58P4119A8UN P58P4119A7CN |
| 13 |  | P58024001K01 |
| 14 |  | P58P4118AW05 P58P4118A8UN P58P4118A7CN |
| 15 |  | P58106000K01 |
| 16 |  | P58105001K01 |
| 17 |  | P58P4120AW05 P58P4120A8UN P58P4120A7CN |

| | | RX330 |
|----|---|--------------|
| 18 |  | P58P4179AK01 |
| 19 |  | P58X330C0000 |
| 20 |  | P581031035PR |
| 21 |  | P5816300160A |
| 23 |  | P581160049B1 |
| 24 |  | P58P4122AK01 |
| 25 |  | P5816300121A |
| 27 |  | P58030001K01 |
| * |  | P584150006W1 |
| * |  | P58PF5620P01 |
| * |  | P58003689W05 |
| * |  | P53RX0339W05 |
| | | P53RX03398UN |
| | | P53RX03397CN |

ASME COMPLIANT SUCTION FITTING INFORMATION

PSF-100A and PSF-100B Suction Outlet Fitting (For Aboveground Pool)

1. PSF-100A and PSF-100B Suction Outlet Fitting are certified by IAPMO in accordance with the ASME/ANSI/APSP/ICC-16 2011 **Suction Fittings for Use in Swimming Pools, Wading Pools, Spas, and Hot Tubs.**
2. This is a submerged suction outlet fitting for use with aboveground swimming pool.
3. For single drain only. Use only ONE outlet fitting for each pump.
4. Do not locate this suction outlet fitting on sitting areas or on the backrest for such seating area.
5. Install this outlet fitting at location recommended by the pool manufacturer. Maximum height 1.8 m from the ground.
6. The maximum allowable flow rate of this suction outlet fitting is 24 gallons per minute (1,440 gallons per hour).
7. Connection hose:
 - a. Model PSF-100A is to be connected with 1 ¼" (31.8mm) diameter hose.
 - b. Model PSF-100B is to be connected with 1 ½" (38.1mm) diameter hose.
8. The suction outlet fitting is to be mounted at the suction outlet fitting opening as specified by the manufacturer of the aboveground pool. The diameter of this opening should be within the range of 1.77" to 1.85" (45mm to 47mm). Refer to the following diagram for detailed assembly instructions:

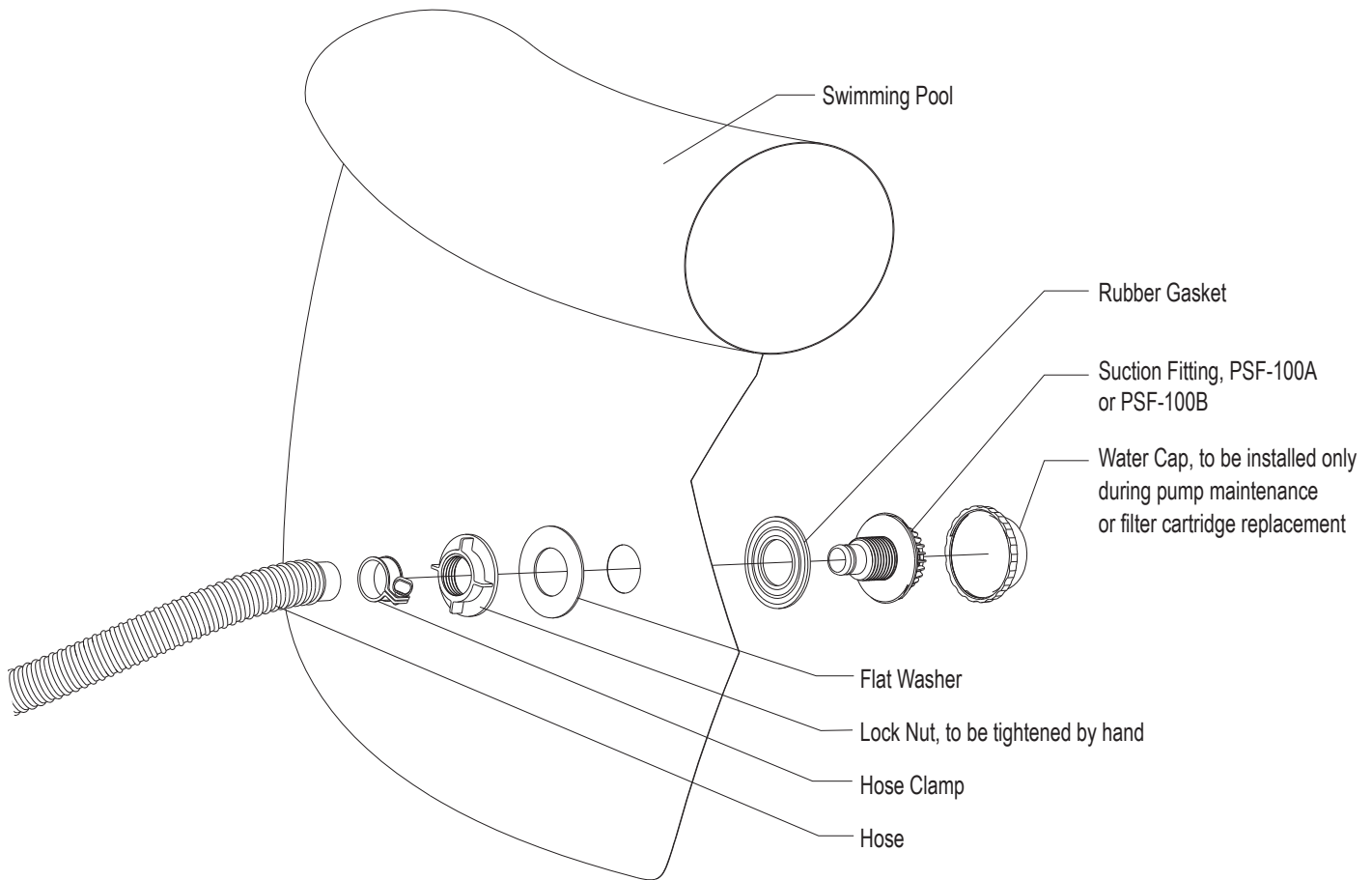

9. PSF-100A or PSF-100B Suction Outlet Fitting is to be replaced every 5 years.
10. No tool is required for installation.
11. Service & winterizing instructions:
 - a. **CAUTION! DO NOT EXCEED THE MAXIMUM ALLOWABLE FLOW RATE: 24 gallons per minute (1,440 gallons per hour)**
 - b. Carefully observe and inspect the suction outlet fitting for damage and tampering. Missing, broken or cracked suction outlet fitting must be replaced before each use of your pool.
 - c. Loose suction outlet fitting should be reattached or replaced before each use of your pool.
 - d. Remove and store the suction outlet fitting assembly if temperatures are expected to fall below 32°F (0°C).